

What is Important in Foundations of Earthquake-Resistant Buildings?

Selecting Site for Earthquake-Resistant Buildings

The site of a building should be free from any collateral damage due to earthquake-related effects. Ideal sites are:

- Away from a potential *fault rupture zone*;
- Above the level of *inundation under tsunami waves* generated in the adjoining ocean by earthquakes (Figure 1);
- Beyond the forest or wooded areas with potential *fire hazard* arising from earthquakes; and
- Free from detrimental earthquake actions in the ground, like *liquefaction, settlement and lateral spreading* (See IITK-BMTPC Earthquake Tip 31).

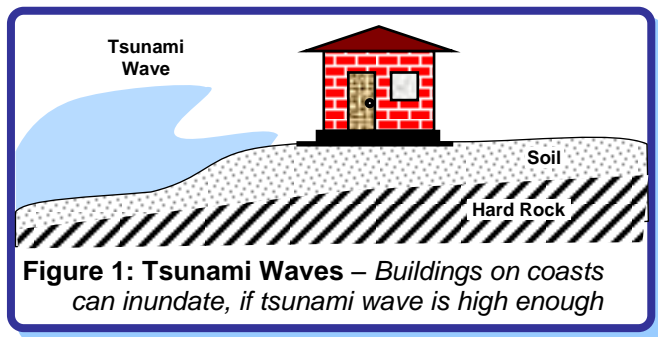

Even if the site is devoid of the above, steep slopes or vertical cuts in natural hills (otherwise safe under other loads acting on them) can slide during earthquakes (Figure 2). Vulnerable soil embankments can *slide* or *spread laterally* due to liquefaction. Other earthquake hazards at hill slope sites include *rolling stones* and *debris*. When the ground shakes underneath *buildings with elongated plan or long span structures* (e.g., suspension bridges), the motion at different supports may not be *synchronous*. Differential shaking of such structures at their supports induces additional effects, and should be accounted for in their design.

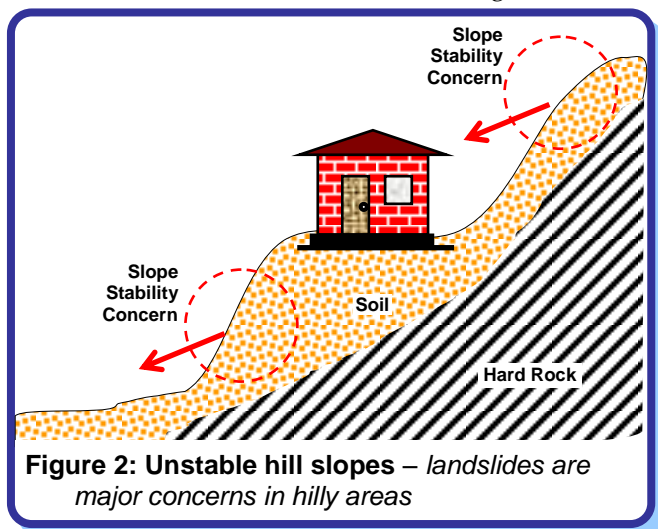

Effect on Ground Shaking on Building Site

Even if local soil stratum underneath a proposed structure is stable, ground shaking may be modified when earthquake waves propagate through the soil overlying rock layers; this phenomenon is referred to as *Site Effect*. Even when shaking at the base rock is *moderate*, the motion at a site may be amplified by soil above rock, and this needs to be accounted for in design. *Site effect* was noticed first in the 1819 Kutch earthquake in India. It was very prominent in 1985 earthquake that affected Mexico City; ground response was amplified by up to 7-8 times at building sites located on lake bed (which was akin to a bowl of jelly) in contrast to those located on hard rock (Figure 3) in Mexico City. *Peak Ground Acceleration (PGA)* is a measure of severity of shaking of ground. During the 1985 earthquake, PGA at soft soil site (SCT) was significantly larger than at rocky site (UNAM) (Figure 3b).

Amplification of ground motion depends on soil properties (e.g., shear modulus, damping, soil layers and their properties, saturated *versus* dry soil, and loose *versus* dense soil), and ground motion characteristics. In general, stiff soils have lower amplification, while soft soils higher. Seismic design codes provide design spectra for underlying soil strata of different soil types.

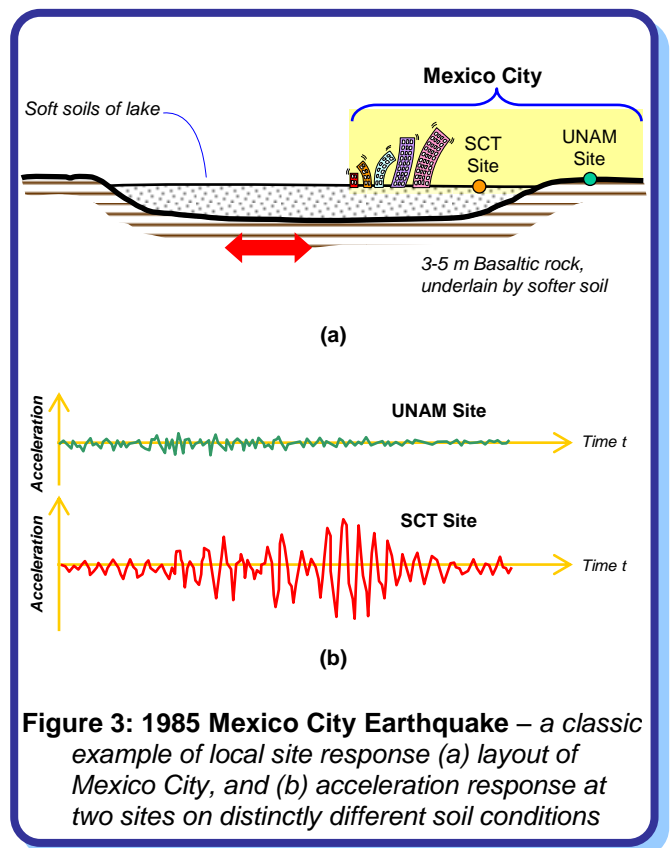

Seismic Design of Foundations

No structure can perform well, if it does not have a good foundation supported on strata that is stable during earthquakes. All principles applicable in foundation design of structures subjected to gravity loads, are applicable in foundation design of earthquake-resistant structures also. Concepts of foundation engineering, like *Bearing Capacity* and *Settlement Criteria*, are relevant to earthquake-resistant buildings also. Thorough geotechnical investigations at the site are a must for most design projects. In addition to traditional *Standard* and *Cone Penetration Tests*, other in-situ tests (e.g., *Shear Wave Velocity Test* and *Pressure-meter Test*) may be performed.

Depending on geotechnical conditions, structural configuration and loads, a suitable type of foundation must be chosen. If soil type is hard, isolated footings may suffice under individual columns. But, these foundations must be tied to each other with beams at top of footings or within the footing depth to resist relative movement between column bases (Figure 3). On the other hand, if soil underneath is soft, other foundation types may become necessary, e.g., raft or pile foundations.

If the site is susceptible to liquefaction, either ground improvement must be undertaken or the foundation must be carefully designed, such that it can carry the load even after the vulnerable soil layers have liquefied (Figure 4). For instance, in case of pile and well foundations, layers susceptible to liquefaction should be neglected in estimating stiffness and strength of the soil system.

In case of lateral spreading, investigations beyond the property boundaries (lines) of the building under consideration may become necessary, especially in when plots are small. Also, lateral thrust offered by liquefied soil layers must be included in estimating force demands on foundations.

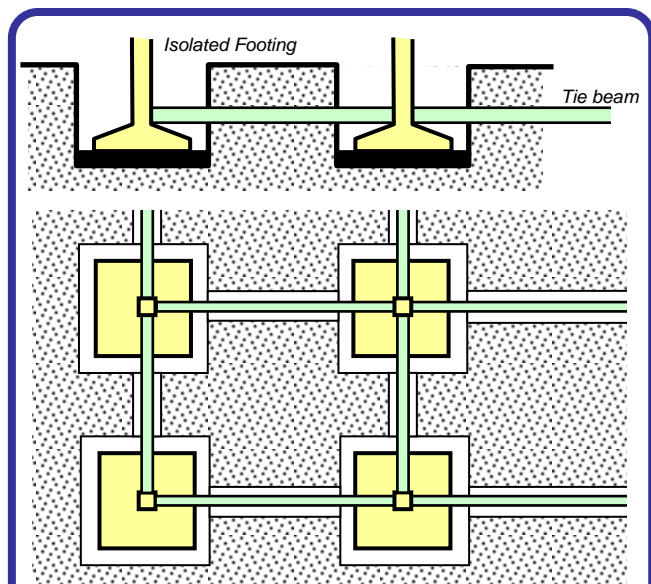

Figure 3: Good foundation design practice in non-liquefiable soil conditions – RC tie-beams between columns at the top of the isolated footings

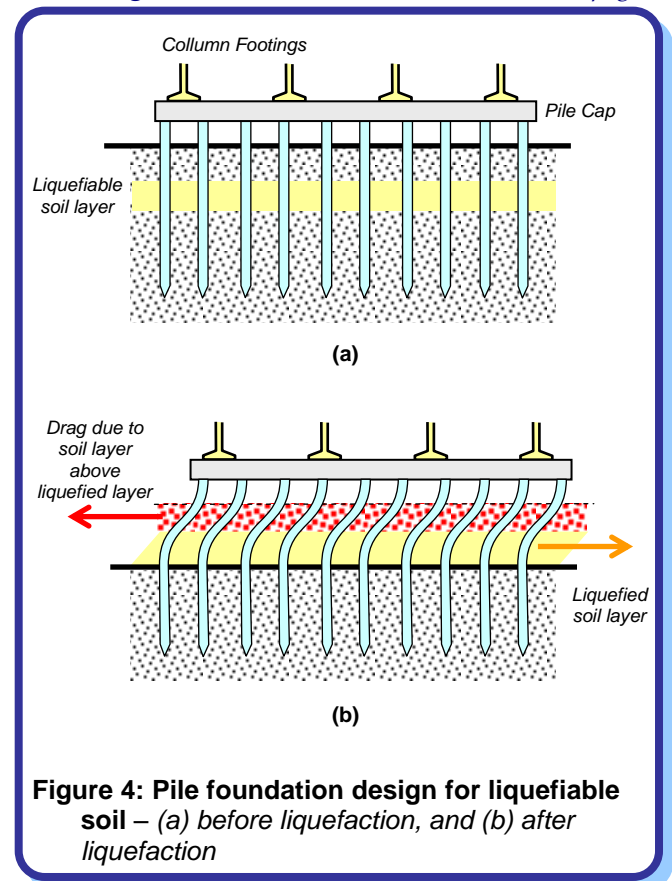

Figure 4: Pile foundation design for liquefiable soil – (a) before liquefaction, and (b) after liquefaction

Capacity Design of Foundations

It is difficult to inspect and repair foundations after a severe earthquake. Further, damage to foundation can be detrimental to the stability of the structure. Hence, in seismic design, column damage in columns is preferred over foundation damage during strong shaking. This is achieved by adopting *Capacity Design Concept* (See IITK-BMTPC Earthquake Tip 9); the foundation system needs to be designed for loads higher than the ultimate flexural capacity of columns (Figure 4) or of structural walls.

Related IITK - BMTPC Earthquake Tip

Tip 9: How to make buildings ductile for good seismic performance?
Tip 31: Why do buildings sink into the ground during earthquakes?

Resource Material

Kramer, S.L., (1996), *Geotechnical Earthquake Engineering*, Prentice Hall, Inc., New Jersey, USA
Towhata, L., (2008), *Geotechnical Earthquake Engineering*, Springer-Verlag, Berlin

Authored by:

C.V.R. Murty

Indian Institute of Technology Jodhpur, India

Sponsored by:

Building Materials and Technology Promotion Council, New Delhi, India

This release is a property of IIT Kanpur and BMTPC. It may be reproduced without changing its contents with due acknowledgement. Suggestions or comments may be sent to: nicee@iitk.ac.in. To see all IITK-BMTPC Earthquake Tips, visit www.nicee.org or www.bmtpc.org.